

ELECTRO-MAGNETIC GATE LOCK

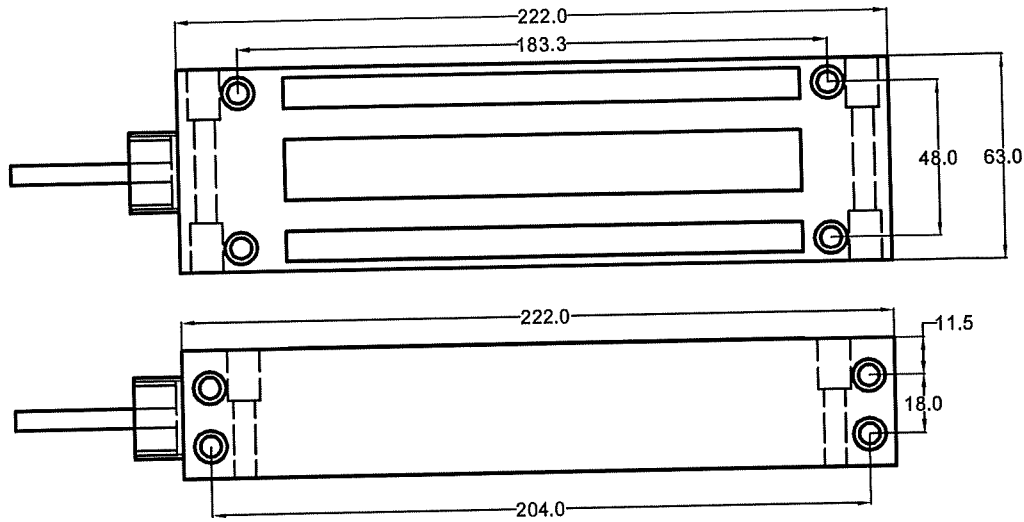

WIRING INSTRUCTION: READ CAREFULLY

- (1) For 12V: Connect the red/black wires, green/orange wires and connect 12V source.
- (2) For 24v: Short black/green wires and connect red and orange wires to 24V source.
- (3) Reed switch dry contacts are rated max 3W (max switching contact 0.25A) at 30VDC/AC for safe operation. Do not exceed this rating.

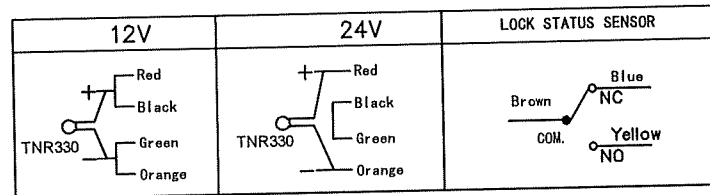

Picture	Quantity	Specification	SERIES
	1	ALUM SPACER (43L*16OD*12.8IDmm)	●
	1	ALLEN KEY 5mm	●
	2	STEEL WASHER 22mm DIA	●
	1	ARMATURE BOLT RECEIVER M8*41mm	●
	1	ARMATURE BOLT M8*45mm W/RUBBER	●
	2	GUIDE PIN 5*16mm	●
	4	M6*50mm FIXING SCREW (NYLOCKED)	●
	1	TNR330	●
	1	RUBBER WASHER 15(OD)*9(ID)*4(H)mm	●
	4	STEEL WASHER 10mm DIA	●
	4	RUBBER T=5mmOD=10.5	●
	4	M6*30mm FIXING SCREW (NYLOCKED)	●

*included in fixed pack and must be fitted if pcb supplied by others

Mounting Installation Series Magnetic Locking Devices

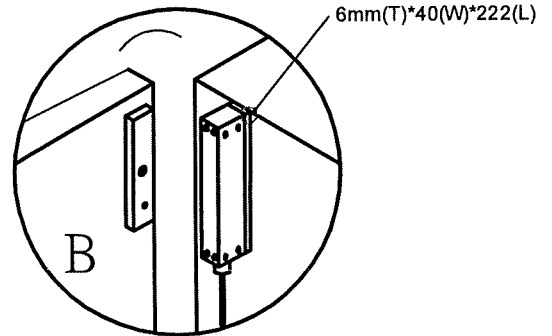
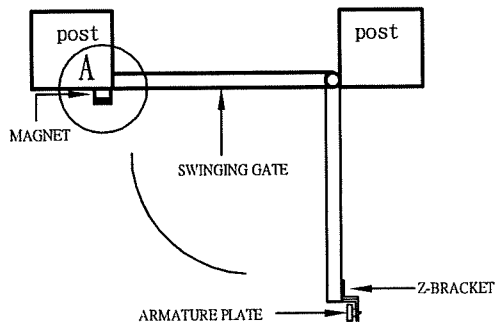
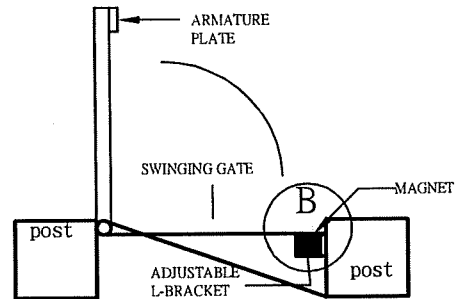
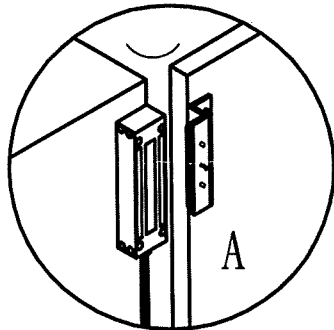

6mm(T)*40(W)*222(L)

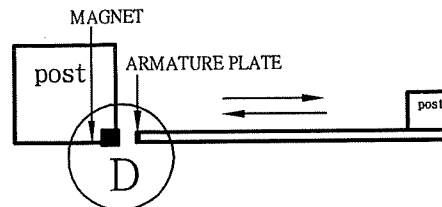
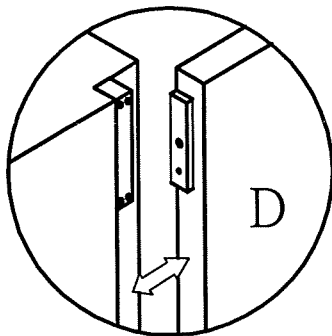
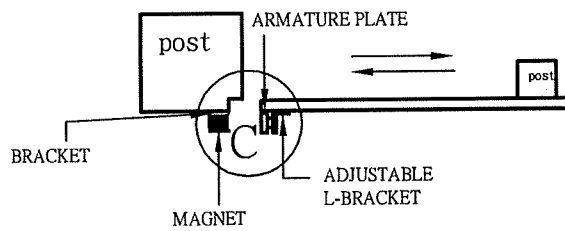
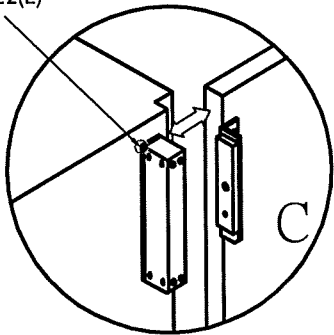

A suitable thread lock should be applied to all fixing screws

Mounting Installation Series Magnetic Locking Devices

Side mount

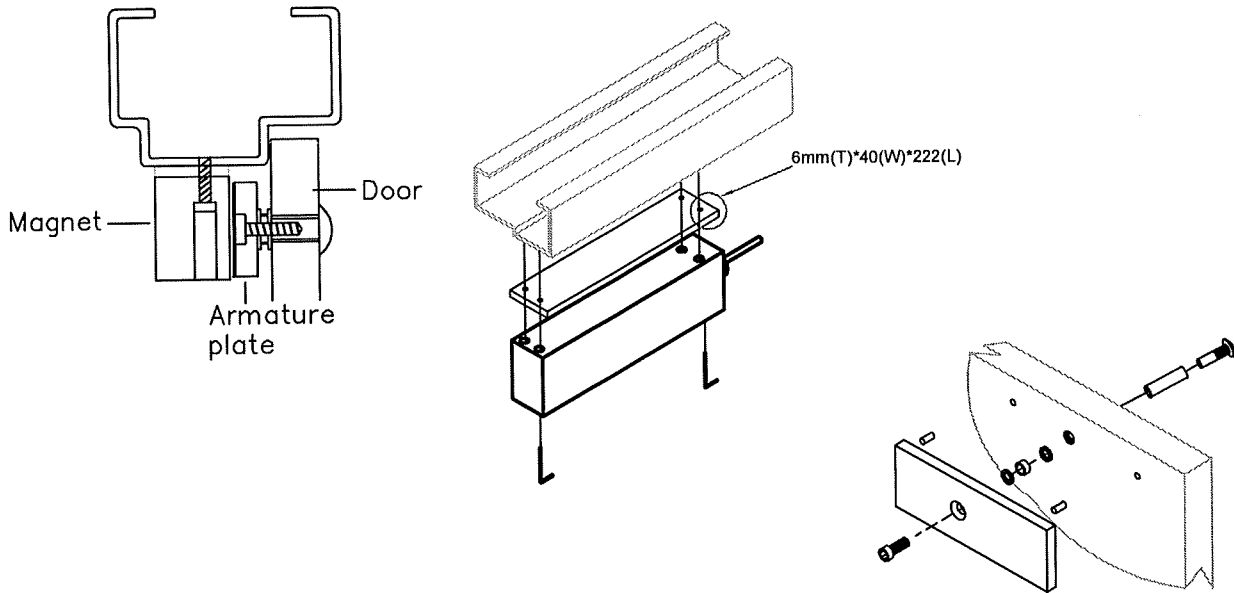

Face mount

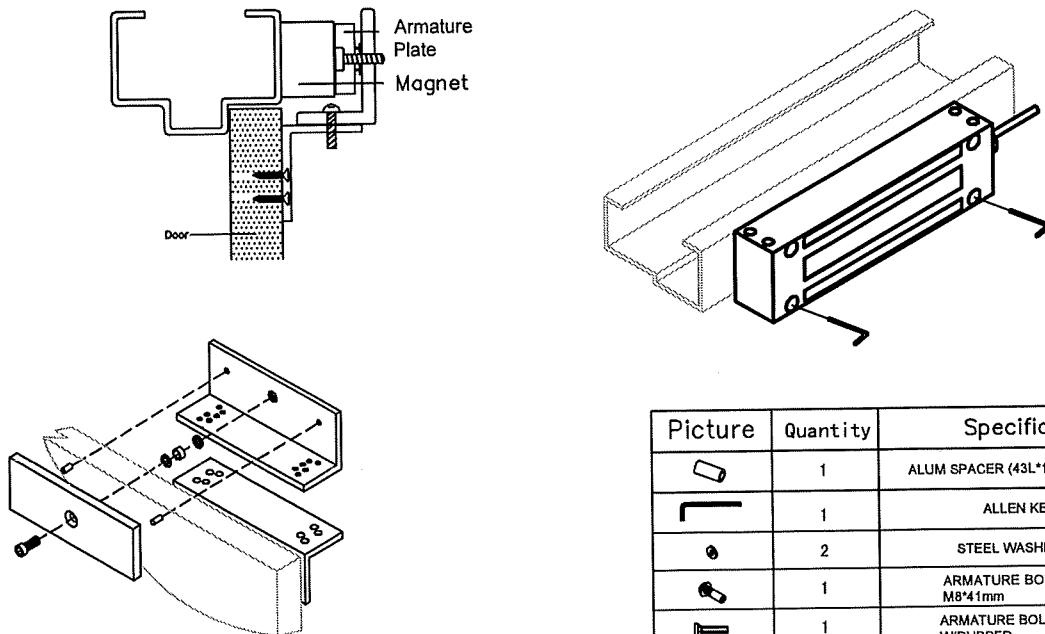

Picture	Quantity	Specification	SERIES
	1	ALUM SPACER (43L*16OD*12.8IDmm)	
	1	ALLEN KEY 5mm	
	2	STEEL WASHER 22mm DIA	
	1	ARMATURE BOLT RECEIVER M8*41mm	
	1	ARMATURE BOLT M8*45mm W/RUBBER	
	2	GUIDE PIN 5*16mm	
	4	M6*50mm FIXING SCREW (NYLOCKED)	
	1	TNR330	
	1	RUBBER WASHER 15(OD)*9(ID)*4(H)mm	
	4	STEEL WASHER 10mm DIA	
	4	RUBBER T=5mmOD=10.5	
	4	M6*30mm FIXING SCREW (NYLOCKED)	

