

Instructions For Magnetic Locking Devices

Important: Please Read Before Attempting To Install Magnetic Lock

- A. Handle the equipment with care, damaging the mating surfaces of the magnet or armature plate may reduce locking efficiency.
- B. The magnet mounts rigidly to the door frame. the armature plate mounts to the door with hardware .kit provided that allows it to pivot about its center to compensate for door wear and misalignment.
- C. Template use must take place with the door in its normally closed position.
- D. Before installing, please add the thread locker to all screws. Firmly tighten the screws to avoid fastening loosen.

Typical Installation

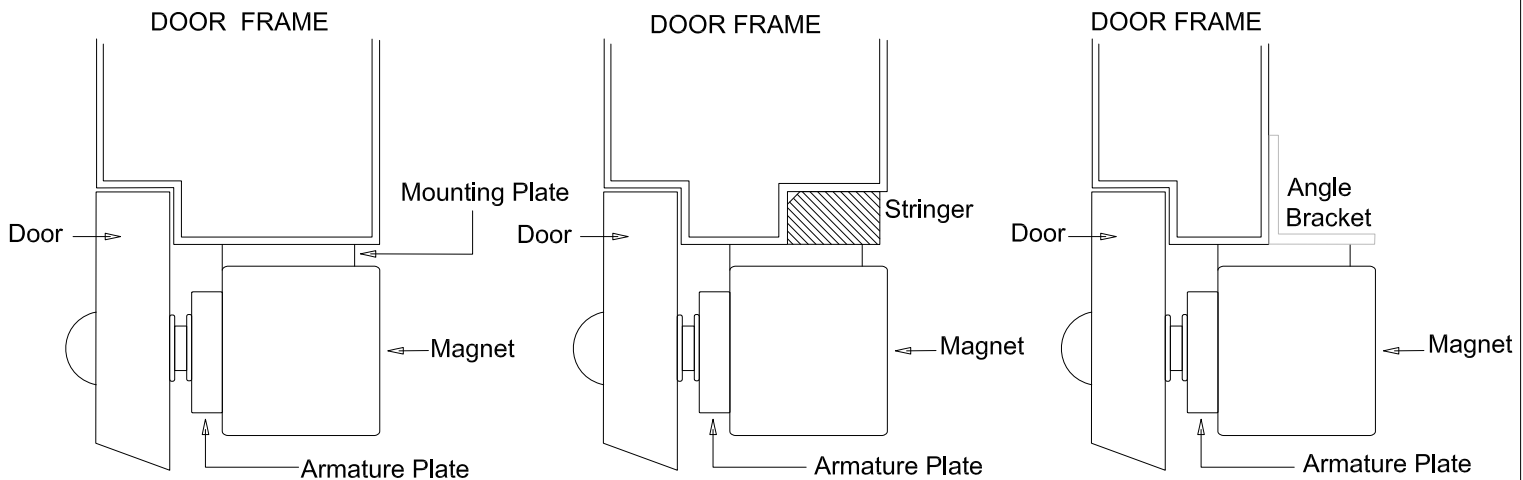

Armature Plate Mounts To The Door

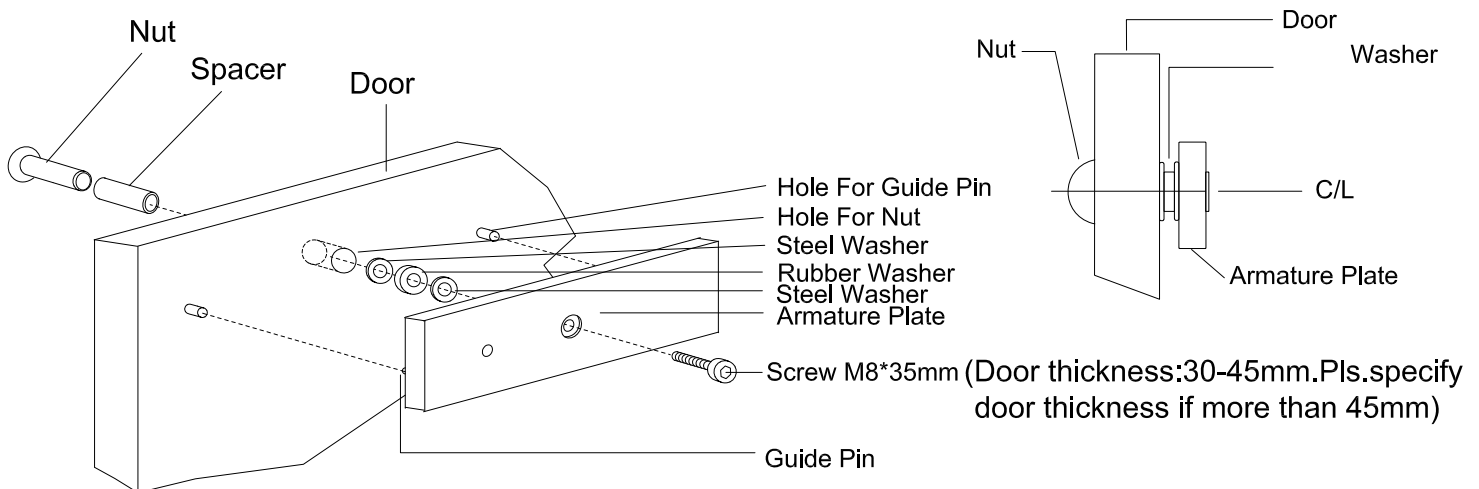

****Important :** Fix the armature plate not too tightly and make the rubber washer more flexible, in order to make the armature plate automatically adjust its proper position with the magnet.