

IMPORTANT

Please read the instructions carefully prior to installation. It is important to follow the instructions precisely to ensure the lock and strike plate are correctly positioned.

ELECTRICAL PREPARATION

Always ensure the correct transformer and cable gauge is specified and used.

ELECTRICAL SPECIFICATION

Power To Open (PTO) Wiring Connections	
BLACK - 0 volts d.c.	
BLUE - Access Control (PTO)	
RED - Positive Continuous Supply	
PURPLE - (COM)	
WHITE - (NO)	
ORANGE - (NC)	
Power To Lock (PTL) Wiring Connections	
BLACK - 0 volts d.c.	
BLUE - Access Control (PTL)	
RED - Positive Continuous Supply	
PURPLE - (COM)	
WHITE - (NO)	
ORANGE - (NC)	

Connections - 3 Wire Control:

- Positive voltage should be connected to the RED wire providing permanent power.
- Negative voltage should be connected to the BLACK wire.
- Positive voltage should be connected to the BLUE wire providing a lock/unlock signal.
- When connected as above the motor will provide power assisted unlocking allowing the bolt to retract with up to 15kg of side load.

- Voltage-free changeover switch contacts are provided for position monitoring.
- When locked, the monitor switch (COM-PURPLE) is connected to (NC-ORANGE).
- The V-Lock is multi-voltage and operates with either 12 to 24VDC power.
- The V-Lock has built-in Reverse Polarity Protection for installer safety.

Note: We only recommend 3 wire connections at all times.

Electrical Specifications

Voltage Supply +/-5% 12Vdc@1000mA

+/-5% 24Vdc@5000mA

Peak Current Draw 1000mA

Standard Current Draw (Locked)

PTL 78mA

PTO 130mA

Lock Monitor Output Voltage free contacts rated 30Vdc/100mA

Operation temperature -10° - +50° @90%RH

CABLE GAUGE REQUIREMENTS

Distance	Cross Cable Dimension	Americal Wire Gauge
5m	0.33mm	AWG22
10m	0.65mm	AWG19
15m	1.04mm	AWG17
20m	1.31mm	AWG16
30m	1.63mm	AWG14
50m	2.05mm	AWG12

MOUNTING APPLICATIONS

The V-Lock can be installed vertically or horizontally, however when used on entry doors exposed to weather, the V-Lock must never be installed vertically.

Never mount the V-Lock in the floor.

1

SELECTING THE MODE CONFIGURATION

STEP A

- Loosen both screws on side of lock body.
- With some force, slide screws in direction required until stop at end of slot is reached.
- Hold in position and re-tighten screws.

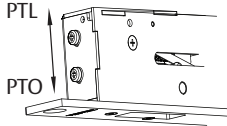

PTL ↑

PTO ↓

STEP B

- Rotate Latch Plate screw beneath the red re-sealable sticker according to orientation shown below:



Turn counter-clockwise 180° for Power-to-Open (Fail Secure)



Turn clockwise 180° for Power-to-Lock (Fail Safe)

STEP C

- Change jumper position on Printed Circuit Board beneath the red re-sealable sticker as shown below:



Power-to-Open (Fail Secure)



Power-to-Lock (Fail Safe)

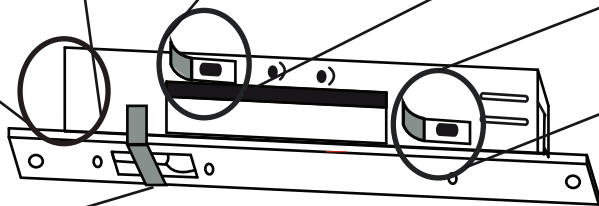

Bolt Label

- **IMPORTANT** - Ensure the correct mode is set before applying power, then follow steps A-C.
- If the lock had been operated previously and the screw in Step B is “missing” refer to the Troubleshooting section.
- Ensure all re-sealable stickers and screws are re-attached after configuration to prevent ingress of dust.

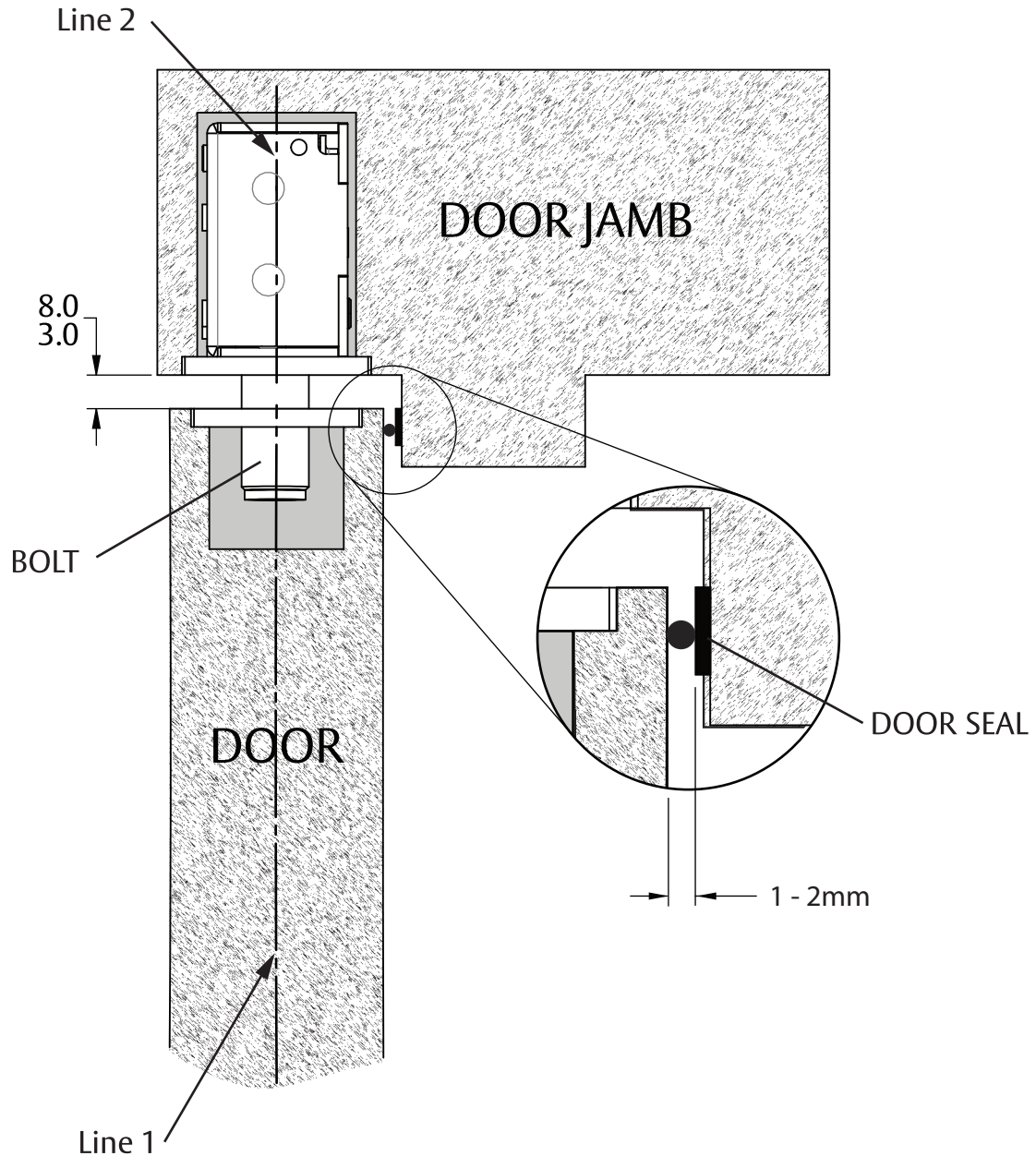

When determining the location of the strike and the lock, always ensure the door seal is not over-compressed against the door jamb.

- Mark Line 1 corresponding to mid-plane of door (ensure there is no over compression between door and frame)
- Mark Line 2 corresponding with Line 1 on the door jamb

Note: the centreline of the door (Line 1) should align with the centre of the V-Lock (Line 2) when the door is in the closed position.

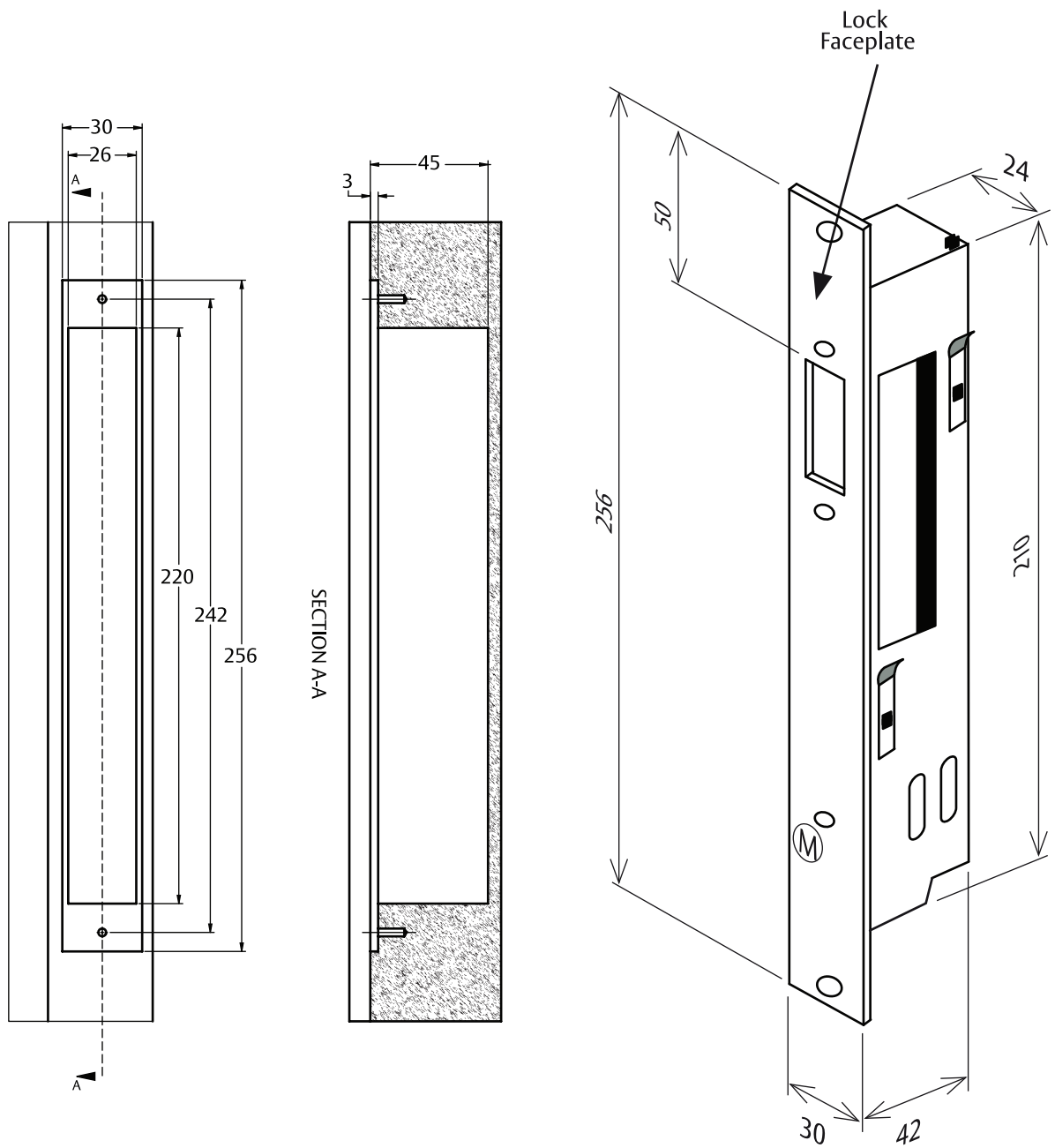

- Mark cut-out of V-Lock symmetrically about Line A.
- Cutout size of face plate must be 256mm x 30mm.
- Prepare door jamb appropriately as shown above.

Note: Thickness of face plate - 3mm.

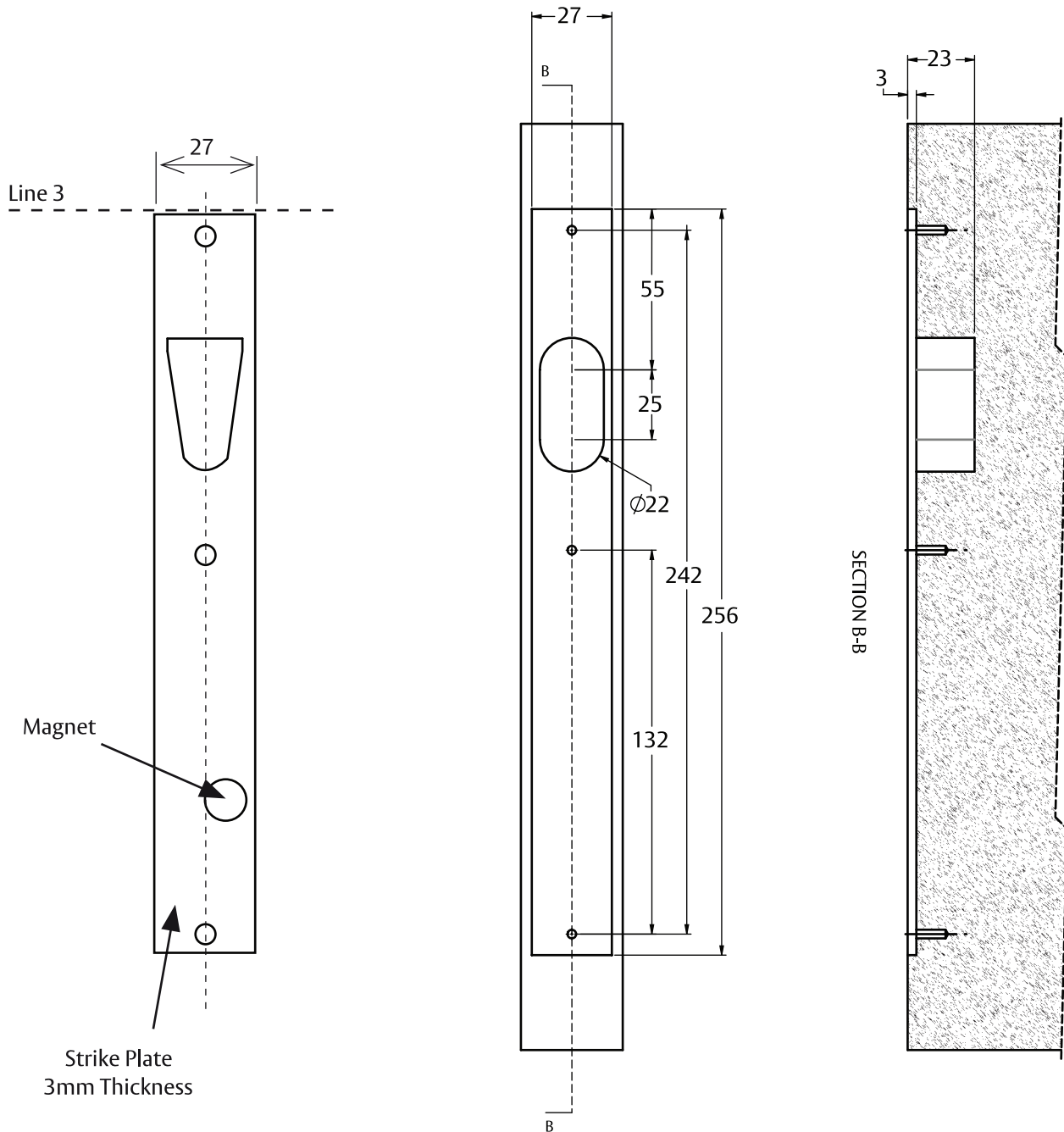

- On the door, mark Line 3 corresponding to the top edge of the lock faceplate (Step 3).
- Mark and recess cutout of strike plate on door symmetrically, using Line B as the centre guide and Line 3 as the height guide.
- Cut out the 22mm wide and 23mm deep cavity for the bolt as shown above.
- Install the strike plate on the door, ensure the door gap is not more than 8mm between the strike plate and the faceplate on the V-Lock.
- Ensure strike plate is securely fastened to increase overall holding force and security of installation.

Note: Thickness of strike plate - 3mm.

Magnet and (M) must line up for V-lock to operate

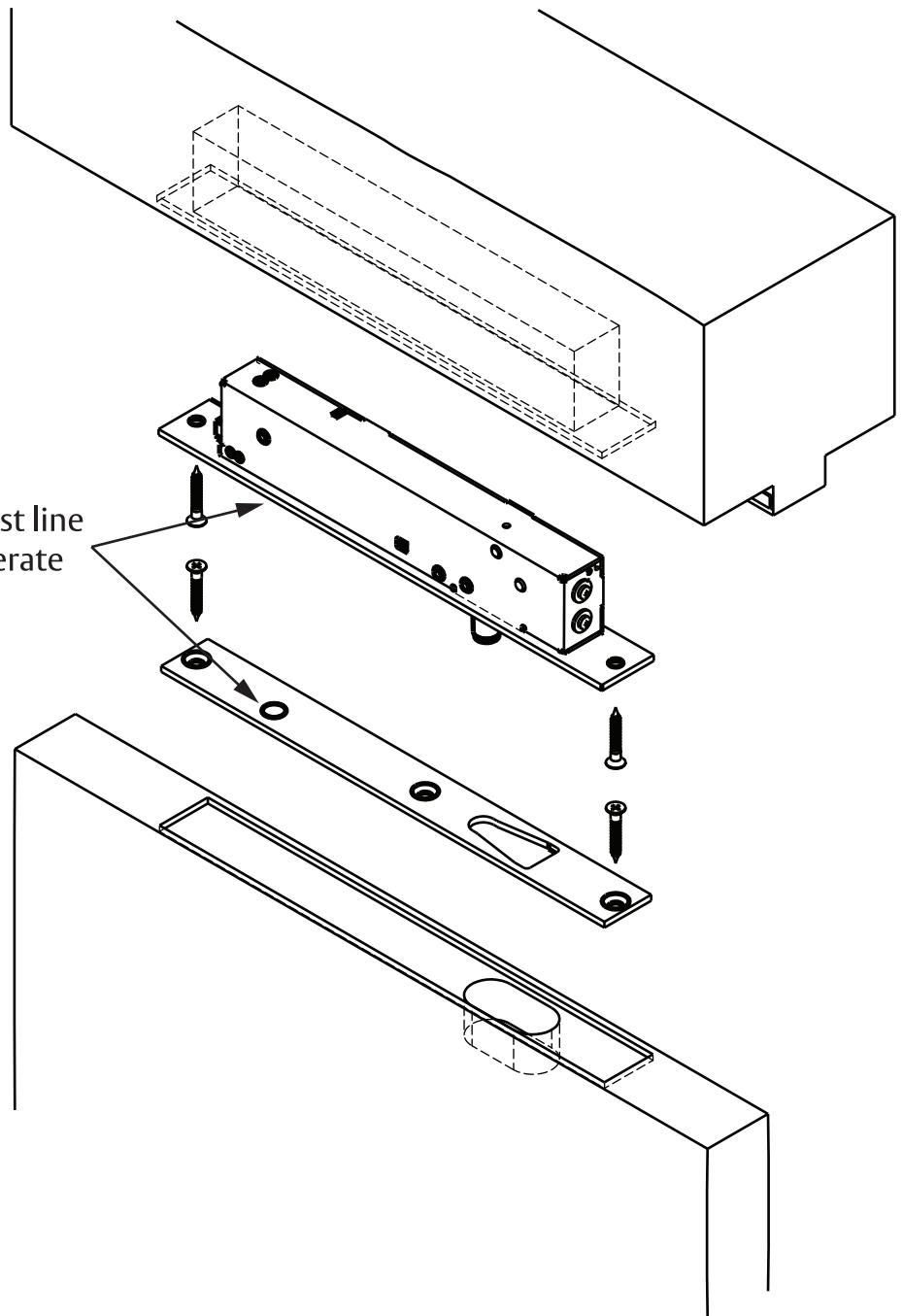

- Ensure all wiring connections are correct and are insulated, make sure the wires do not rub on any sharp edges or do not interfere with any locking mechanism.
- Install the V-Lock into the door jamb as shown above.
- Power up lock, then let the door open and close normally with door closer. When the strike plate magnet comes within locking range, the V-Lock will lock automatically.

IMPORTANT NOTE: Upon testing the V-Lock for the first time, listen if the motor strains. If there is any sort of strain, check if the strike plate and the lock body is aligned as per line 3 in Step 4. (you may be over compressing the door against the jamb/ frame) Adjust the strike or the lock accordingly

Q: The Door is closed but the bolt has not automatically extended and locked into the strike plate.

A: Check the following in no particular order:

- Check the gap between strike and faceplate is between 3-8mm.
- Check the Power supply and Cable Gauge used is to required specification.
- Check that its connected according to PTL or PTO requirements.
- Check that its the correct strike plate used that came with the product.

Q: I'm trying to change the lock from Fail Safe PTL to Fail Secure (PTO). The screw in Step B is missing.

A: If lock had been operated previously, the screw in Step B will not be visible. In order to return the V-Lock back into post manufactured mode follow these steps;

1. Change the jumper setting to PTL mode.
2. Shift the top two screws to PTL mode.
3. Ensure the face plate magnet is aligned with the sensor at all times during this procedure.
4. Apply permanent negative voltage to the lock (Black wire)
5. Connect the Red and Blue wire together and apply (positive) power to these two terminals. (CONTINUE HOLDING IT IN THIS POSITION).
6. The bolt will move, watch the cavity indicated in Step B, CONTINUE HOLDING CONNECTIONS IN THIS POSITION. The screw will be visible, quickly remove all power.
7. Now that the screw is visible as shown in Step B you can rotate the screw.
Note: Retry if screw is not totally accessible.

Q: When the lock attempts to lock it does not lock and return back into the body.

A: Check if the Power supply and Cable Gauge, is to required specification as per Page 1.
Check that the strike plate and the lock body is aligned as per line 3 in Step 4.

Q: When the lock attempts to unlock it does not retract all the way.

A: Check that the cavity is wide enough and there is not any pressure on the lock body.

Other items to check:

- Check that 1000mA power supply is used
- Check that the cable gauge is sufficient between the power supply and the lock as per Page 2
- Check that there is no mechanical interference, thats causing strain on the bolt.

ASSA ABLOY

ASSA ABLOY is the global leader in door opening solutions, dedicated to satisfying end-user needs for security, safety and convenience.

ASSA ABLOY is represented in all major regions, in both mature and emerging markets, with leading positions in Australia, Europe and North America.

As the world's leading lock group, ASSA ABLOY offers a more complete product range of door opening solutions than any other company on the market.

1300 LOCK UP (1300 562 587)
lockweb.com.au

